

# Integrated transformer welding guns

Type **C**  
**AC-MF**

Electrical Drive  
Available

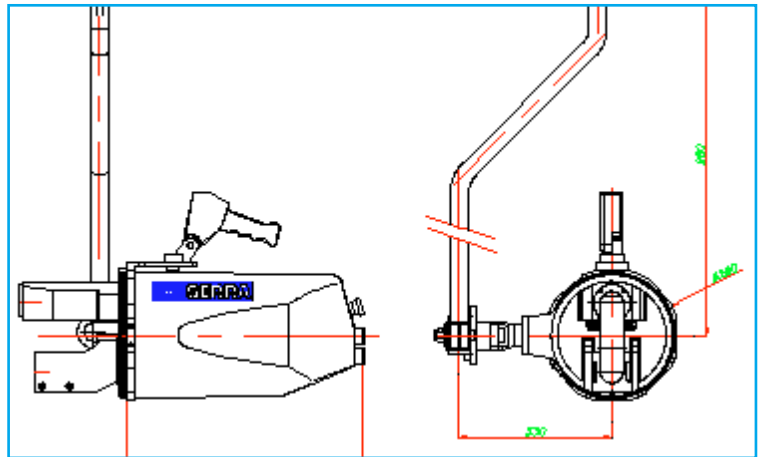

	Pneumatic drive	Electric drive
Power at 50% DC	AC: 45 - 65 kVA • MF: 100 kVA	
Secondary voltage	45 kVA: 7,1 V • 65 kVA : 8,5 V • MF : 9,0 V	
∅ welding cylinder	100 mm	-
Cylinder stroke	100+45 mm	130 mm
Maximum air pressure	6 bar	-
Cooling water consumption	10 l/m	
Clearance between arms	150 mm	
Maximum force	460 daN	750 daN
Weigh 45 kVA gun (ex arms)	57 Kg	60 Kg
Weigh 65 kVA gun (ex arms)	60 Kg	63 Kg

Possible arm configurations

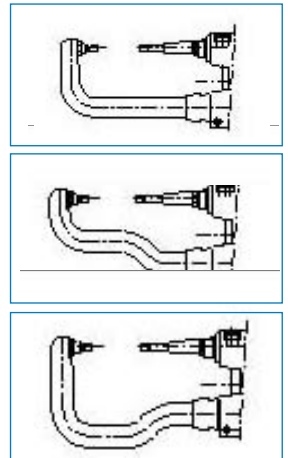

**SERRA SOLDADURA, S.A.**  
Zona Franca, Sector C, Calle D, nº 29.  
E-08040 BARCELONA  
Tel. +34.93.26.17.100 Fax +34.93.26.17.110  
www.serrasold.com

**QUALITY MANAGEMENT**  
Certificate  
Voluntary participation in regular monitoring according to ISO 9001:2000



**ENVIRONMENTAL MANAGEMENT**  
Certificate  
Voluntary participation in regular monitoring according to ISO 14001

