

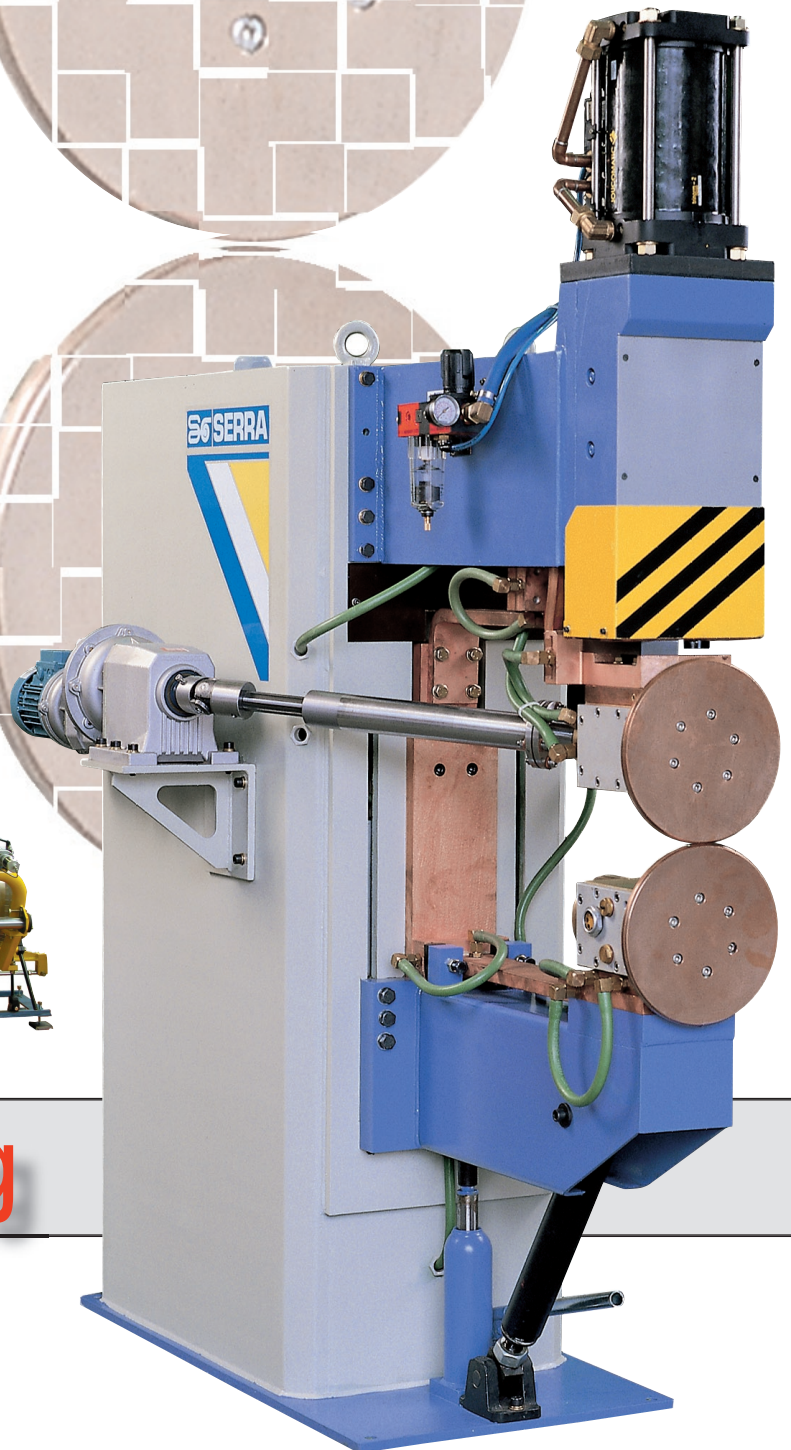

V.0805

series gamma

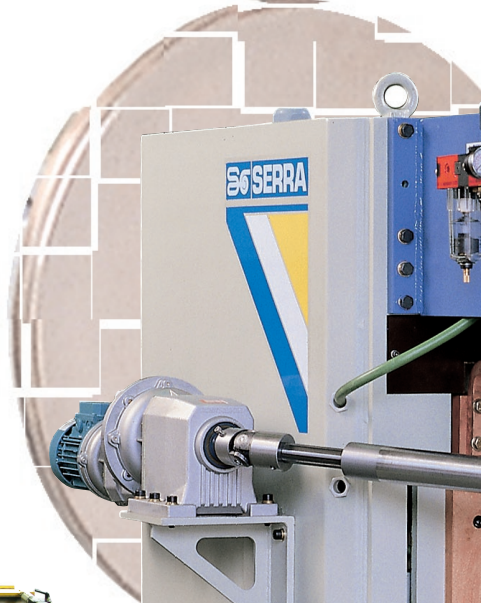
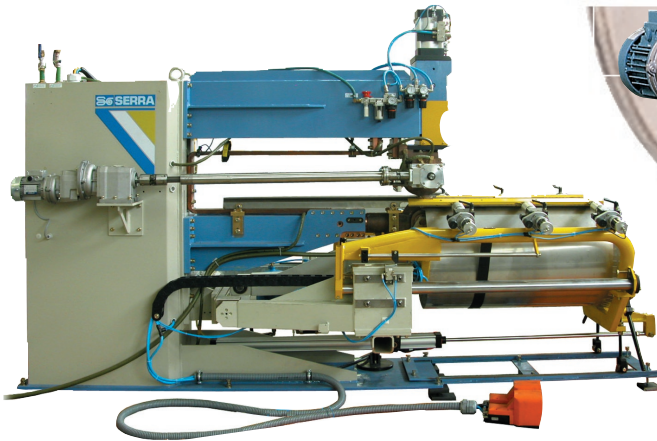
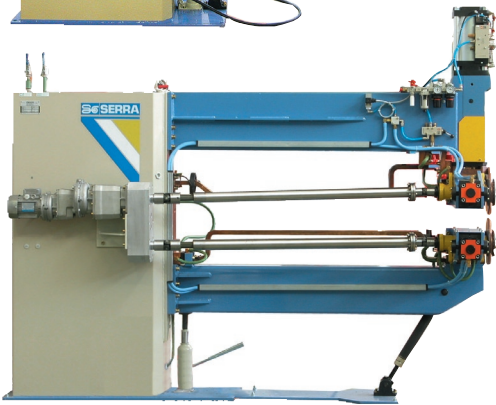
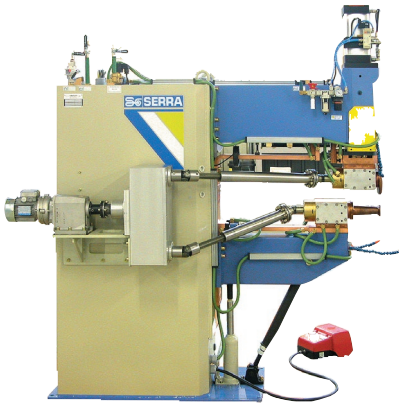

Seam Welding



series

gamma

Equipment:

- Lower arm (except longitudinal type)
- Electronic flowmeter

Optionals:

- Increasement 220 V
- Wheel trimmer
- Double drive and differential
- Double peripheral drive

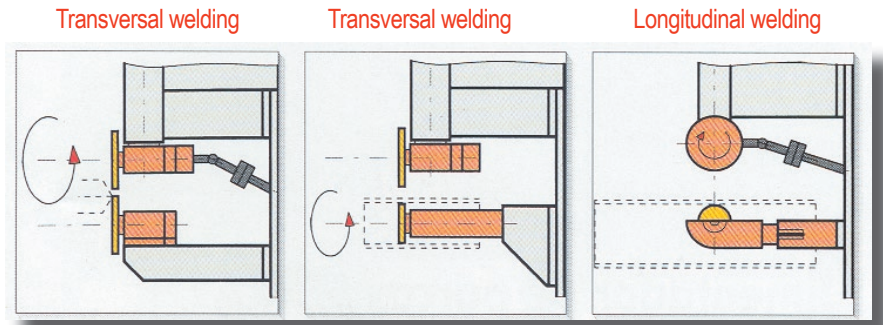

	Ref.	GAMMA 100								GAMMA 200							
		TRANSVERSAL			LONGITUDINAL			MIXED		TRANSVERSAL			LONGITUDINAL			MIXED	
		73101	73102	73103	73104	73105	73111	73106	73107	73108	73109	73110	73113	73114	73115	73117	73118
Power at 50 % D.C.	kVA	130								250							
Cylinder force at 6 bar	daN	750								1200							
Cylinder stroke	mm	100								150							
DIN throat depth (head axe)	mm	600	750	1050	600	750	1050	600	750	600	750	1050	600	750	1050	710	860
Daylight	mm	710	860	1160	600	750	1050	710	860	710	860	1160	600	750	1050	710	860
Max. welding power in Sh.C.	kA	24	19,2	16	24	19,2	16	24	24	24	30	24	24	24	27	24	27
Max. tangential speed	m/min	3,4	4,5	4,5	4,5	4,5	4,5	4,5	4,5	5	6	6	6	6	6	6	6
Min. tangential speed	m/min	0,8	0,8	0,8	0,8	0,8	0,8	0,8	0,8	1,1	1,1	1,1	1,1	1,1	1,1	1,1	1,1
Height	mm	2060	2060	2060	2060	2060	2060	2060	2060	2060	2060	2060	2060	2060	2060	2060	2060
Lenght	mm	1610	1760	2060	1610	1760	1660	1610	1760	1610	1760	2060	1610	1760	2060	1610	2060
Width	mm	722	722	722	722	722	722	722	722	722	722	722	722	722	722	722	722
Wheel diameter	mm	170	170	170	170	170	170	170	170	250	250	250	250	250	250	250	250
Weight	kg	1200	1250	1300	1250	1200	1250	1200	1300	1290	1340	1390	1330	1360	1390	1300	1350
Isolator	-	160	160	160	160	160	160	160	160	160	160	160	160	160	160	160	160
Weld controller	-	SERRATRON 1A															
Power supply	V	400 (50 Hz)															



SERRA SOLDADURA, S.A.

www.serrasold.com

QUALITY MANAGEMENT
Certificate

Voluntary participation in regular monitoring according to ISO 9001:2000



ENVIRONMENTAL MANAGEMENT
Certificate

Voluntary participation in regular monitoring according to ISO 14001



Pol. Ind. Zona Franca, Sector C, Calle D, nº 29. E-08040 BARCELONA Tel. +34.93.26.17.100 Fax +34.93.26.17.110